

SERVICE BULLETIN

AMATEUR RADIO

| SUBJECT | DATE |
|-----------------------------------|--------|
| TS-940S AVR UNIT CAPACITOR CHANGE | 4-8-86 |

In those areas of the country that are subject to large power line voltage fluctuations, excessive voltage may be applied to capacitor C12 on the AVR Unit (X43-1500-00). These voltage fluctuations might exceed the capacitor breakdown voltage. Replacing capacitor C12 with a capacitor having a higher breakdown voltage will help prevent this potential problem.

Procedure:

On the AVR Unit (X43-1500-00) change C12 from a 6800 μ F capacitor to a 5600 μ F 25 v capacitor (C98-2837-05).

AVR UNIT (X43-1500-00) Component side view

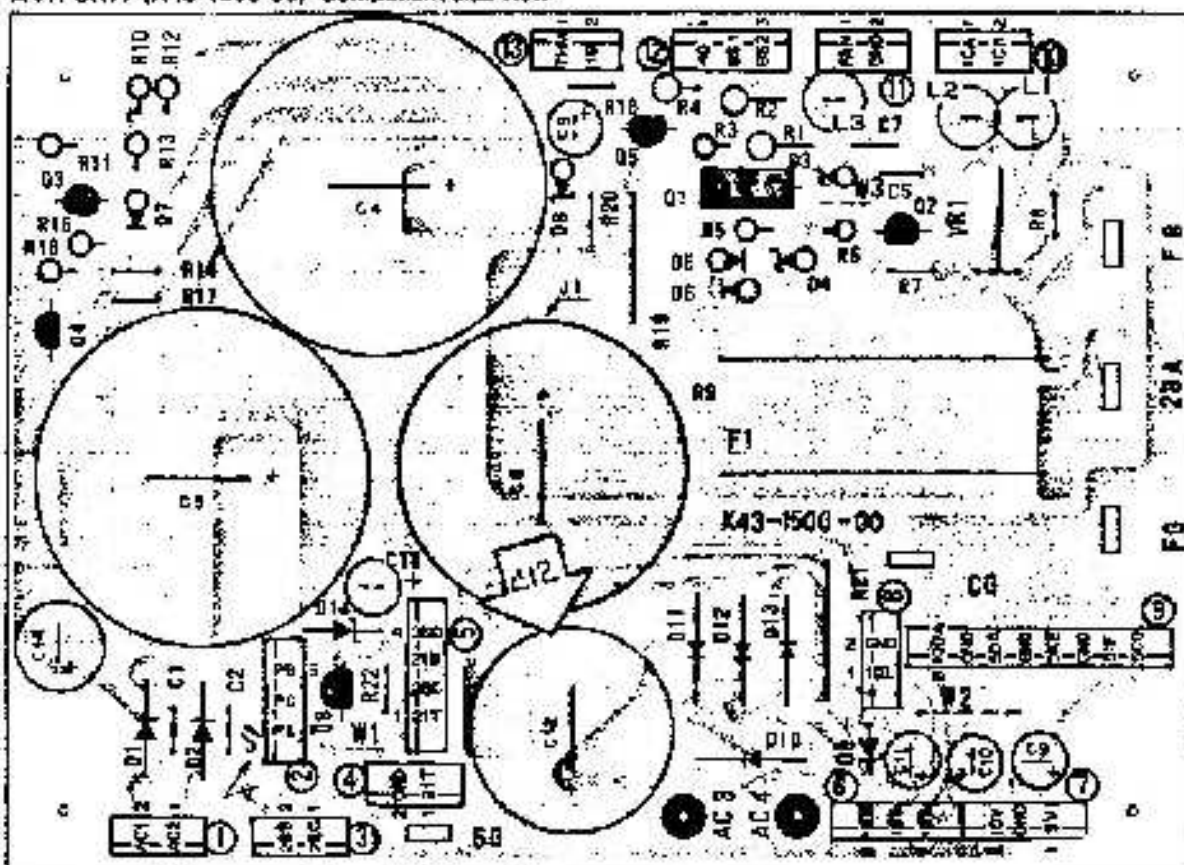

This change is applicable to serial numbers prior to 701XXXX.

Time Required for this modification is 1 hour or less. ©TKC41886CLM

SERVICE BULLETIN

AMATEUR RADIO

SUBJECT TS-940S AGC CIRCUIT IMPROVEMENTS

DATE 6-03-86

The following changes will improve the adjacent channel rejection of the TS-940S when a relatively strong nearby signal is present (S-4 or above).

The AGC switch should remain in the SLOW position for all but high speed data communications. Most CW operations will also benefit from operation in the SLOW position.

Parts Required:

15 k ohm 1/4 watt resistor.....RD14CB2E153J
1 uF 16v Electrolytic.....CE04BW1E010M
1S1555 diode.....V1S1555
.047 uF capacitor.....C91-0119-05

Procedure:

RF UNIT

1. Remove jumper wire JP7 and replace it with the parallel combination of the 15 k ohm resistor and the 1S1555 diode. Pay close attention to polarity.
2. Add the 1 uF capacitor as shown in the diagram.

IF UNIT

Change capacitor C75 from a 1 uF 50 v capacitor to a .047 uF 50v capacitor.

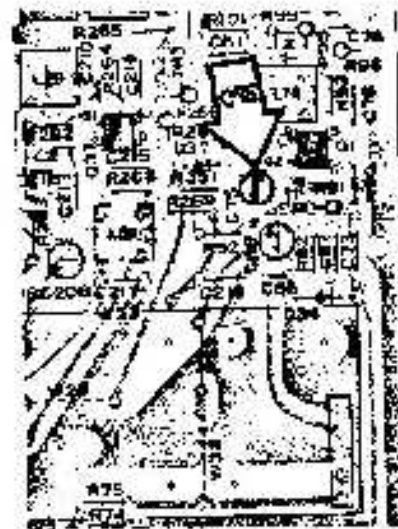
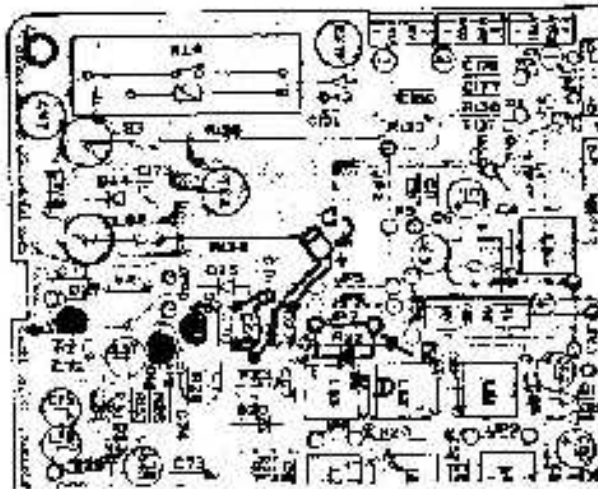
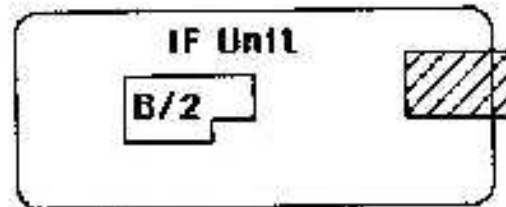
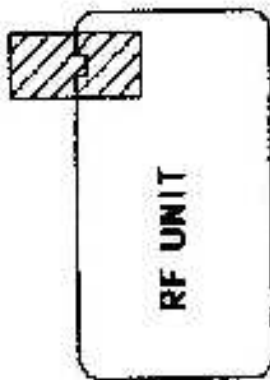
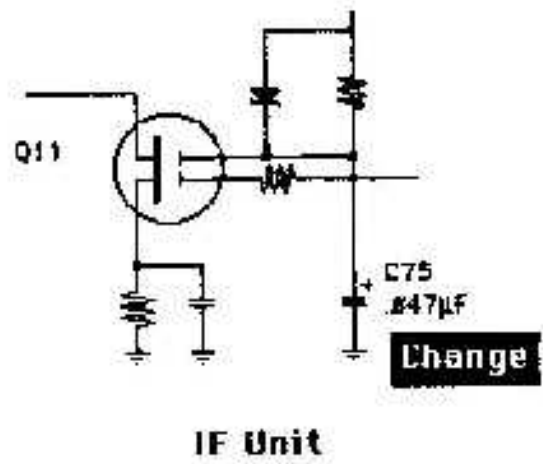
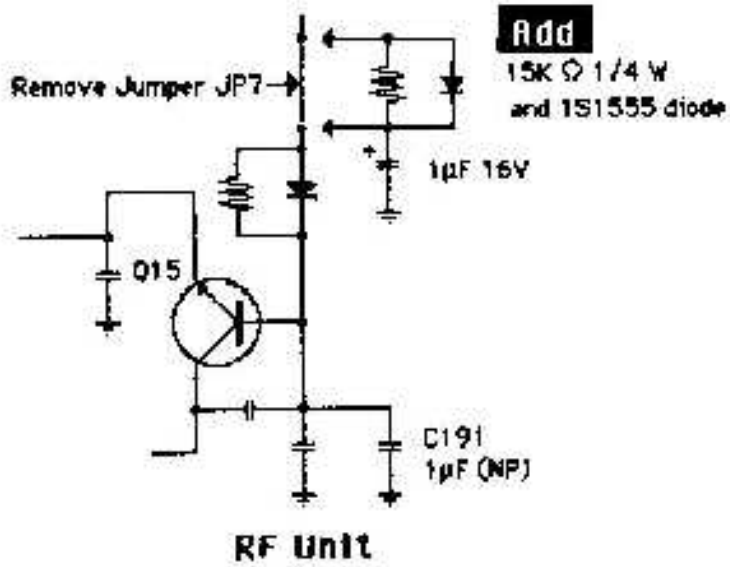

Time required for this modification is 1 hour or less.
©41886TKCLM

KENWOOD

912

SERVICE BULLETIN

AMATEUR RADIO

SUBJECT TB-940S TRANSMITTER HUM IN SSB

DATE
9-15-86

For reports of a low level audio hum superimposed on the normal transmitted audio, especially when the Speech Processor is used perform the following modification.

Parts required

C285 .01 uF 50 v Disc Ceramic capacitor CK45FH1B3Z

Procedure:

On the IF UNIT (X4B-1430-00) make the following changes:

- Cut the foil patterns labeled A-E in figure 1.
- Add the jumper wires labeled F-H in figure 1.
- Add capacitor C285 .01 uF 50 v as shown.

This change will be included on all units shipped after 9-15-86.

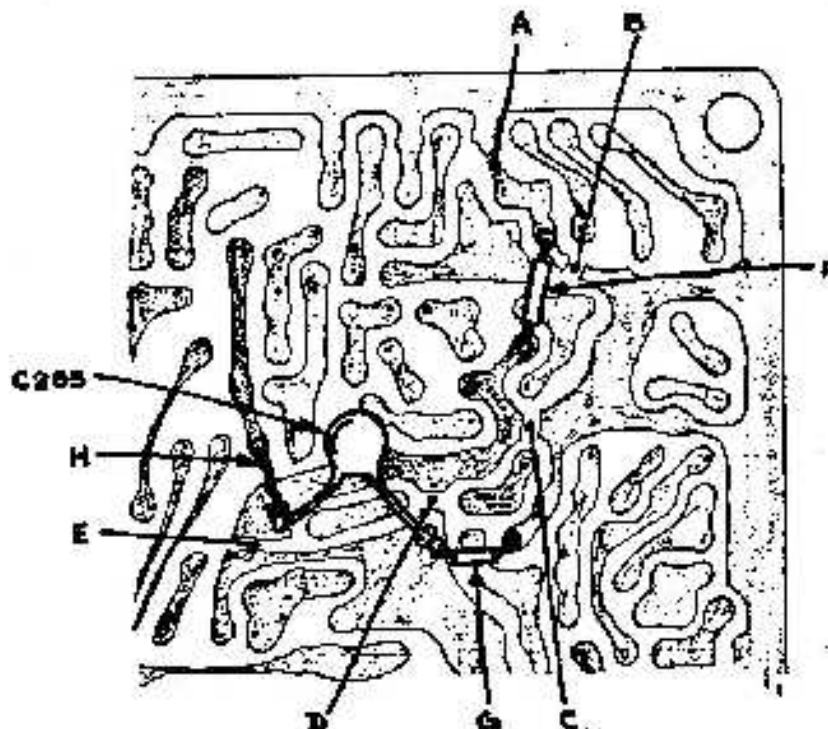

Page 1 of 2

IF UNIT (X48-1430-00)

The heavy dark lines indicate the changes that are required for this modification. We recommend that you compare this schematic with the one provided with the TS-940 Service Manual.

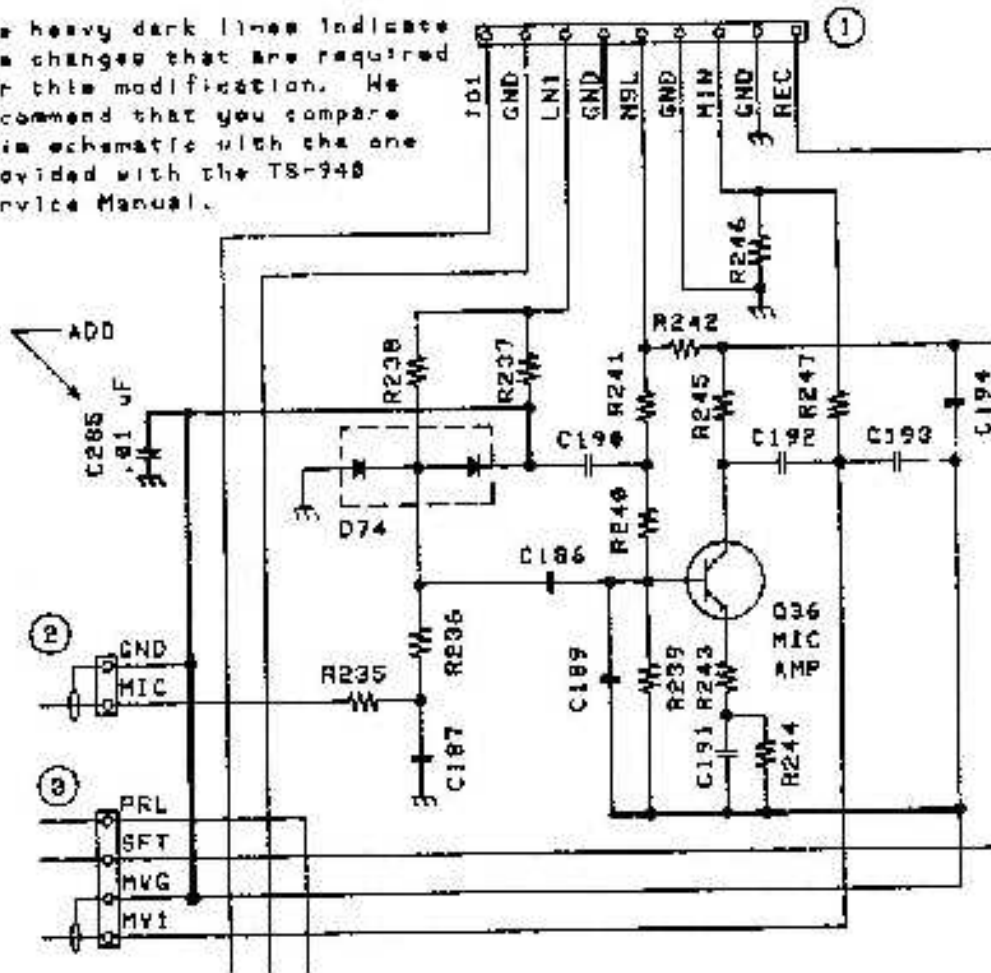

Page 2 of 2

Time required for this modification is 1 hour or less. (C)82086TKDCLM

SERVICE BULLETIN

AMATEUR RADIO

| | |
|------------------------------------------------------|-----------------|
| SUBJECT TS-940S SIGNAL TO NOISE RATIO IMPROVEMENT | DATE 6-28-86 |
|------------------------------------------------------|-----------------|

The following change will reduce the tendency of the Zener Diode in the Noise Blanker circuit to cause an increase in the ambient noise level. This change ensures that no current flows thru this diode in the normal receive position.

Parts required

560 ohm 1/4 watt resistorRD14CB2E561J

Procedure:

On the IF UNIT (X48-1430-00) change R23 from 330 ohms to 560 ohms.

This change will be incorporated in all models beginning with serial number 603XXXX.

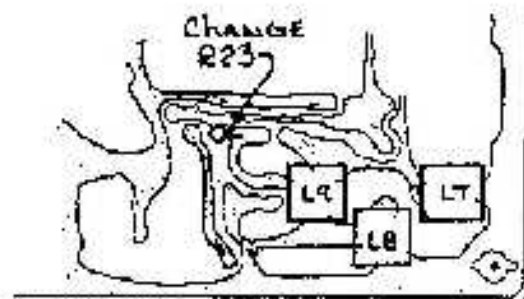
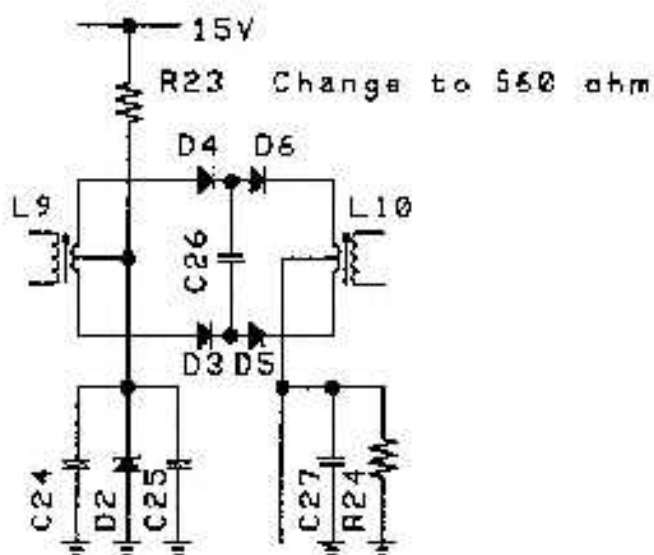

IF UNIT (X48-1430-00)

Time required for this modification is 1 hour or less. (C)B20B6TKCCLM

SERVICE BULLETIN

AMATEUR RADIO

| | |
|-----------------------------------------------------------|----------------|
| SUBJECT TS-940S VCO CARRIER TO NOISE RATIO IMPROVEMENT | DATE 3-2-87 |
|-----------------------------------------------------------|----------------|

The Carrier to Noise ratio of the TS-940S may be improved by the following changes. This bulletin supersedes bulletin number 911 dated September 15, 1986.

Parts required:

PLL UNIT (X50-2020-00)

| | | |
|----------|-----------------------------------|--------------|
| R120,129 | 3.3K ohm 1/8 watt carbon resistor | RD14CB2C332J |
| R121,124 | 680 ohm 1/6 watt carbon resistor | RD14CB2C681J |
| C180,181 | .01 uF disc ceramic capacitor | C91-0117-05 |
| C184,185 | .33 uF 35v Tantalum capacitor | CS15E1VR33M |

RF UNIT (X44-1660-00)

| | | |
|----------|-----------------------------------|--------------|
| R154,155 | 3.3K ohm 1/6 watt carbon resistor | RD14BB2C332J |
| C193,194 | 1 uF 25v Tantalum capacitor | CS15E1EG10M |

Procedure:

On the PLL UNIT (X50-2020-00) remove capacitors C176, C180, and C181. Change resistors R120 and R129 from 470 ohms to 3.3 K ohms. Change resistors R121 and R124 from 1 K ohm to 680 ohms. Change capacitors C184 and C185 from .22 uF to .33 uF 35V tantalum capacitors. Install C180 and C181 in the positions shown in the accompanying diagrams. The use of new capacitors is recommended to improve reliability, don't try to reuse the old capacitors! Capacitors C181 and C180 should be attached to the foil side of the PLL unit.

On the RF Unit (X44-1660-00) install the series RC circuits composed of R154 and C193, and R155 and C194, as shown in the accompanying diagrams. As the diagrams illustrate it is easiest to move C192 and C193 to the foil side of the board and install the series RC circuits on the component side.

This is an optional change and may not be performed under warranty. Time required for this modification is 1.5 hour or less. (C)21887TKCCLM

1 of 3

PLL UNIT

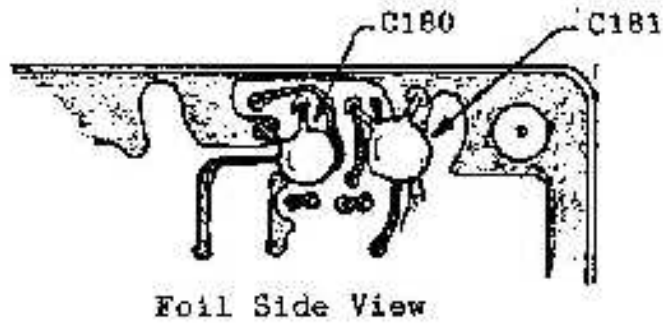
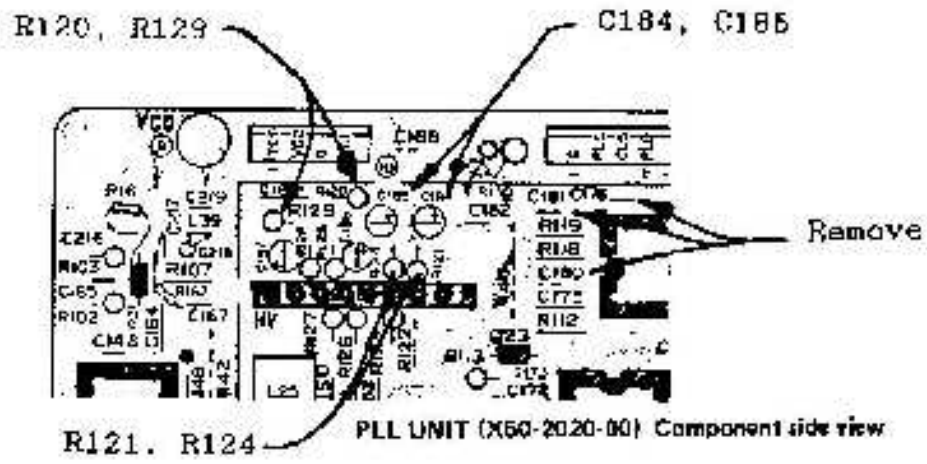

RF UNIT

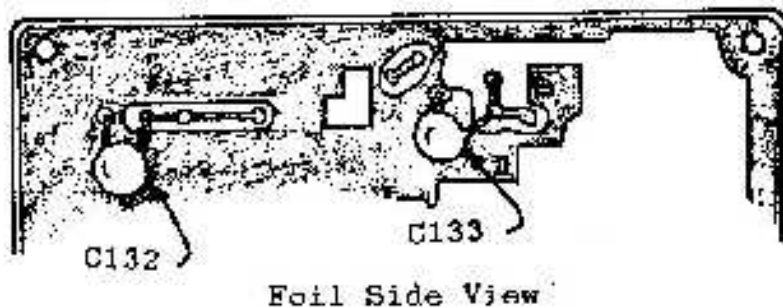
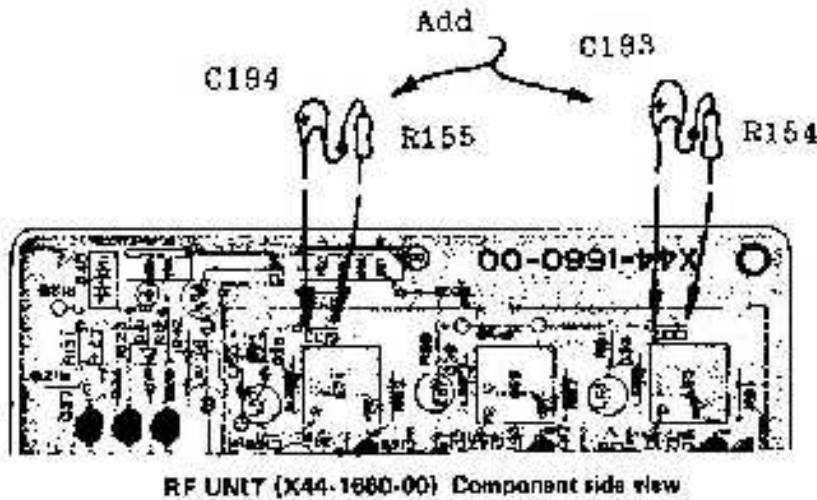

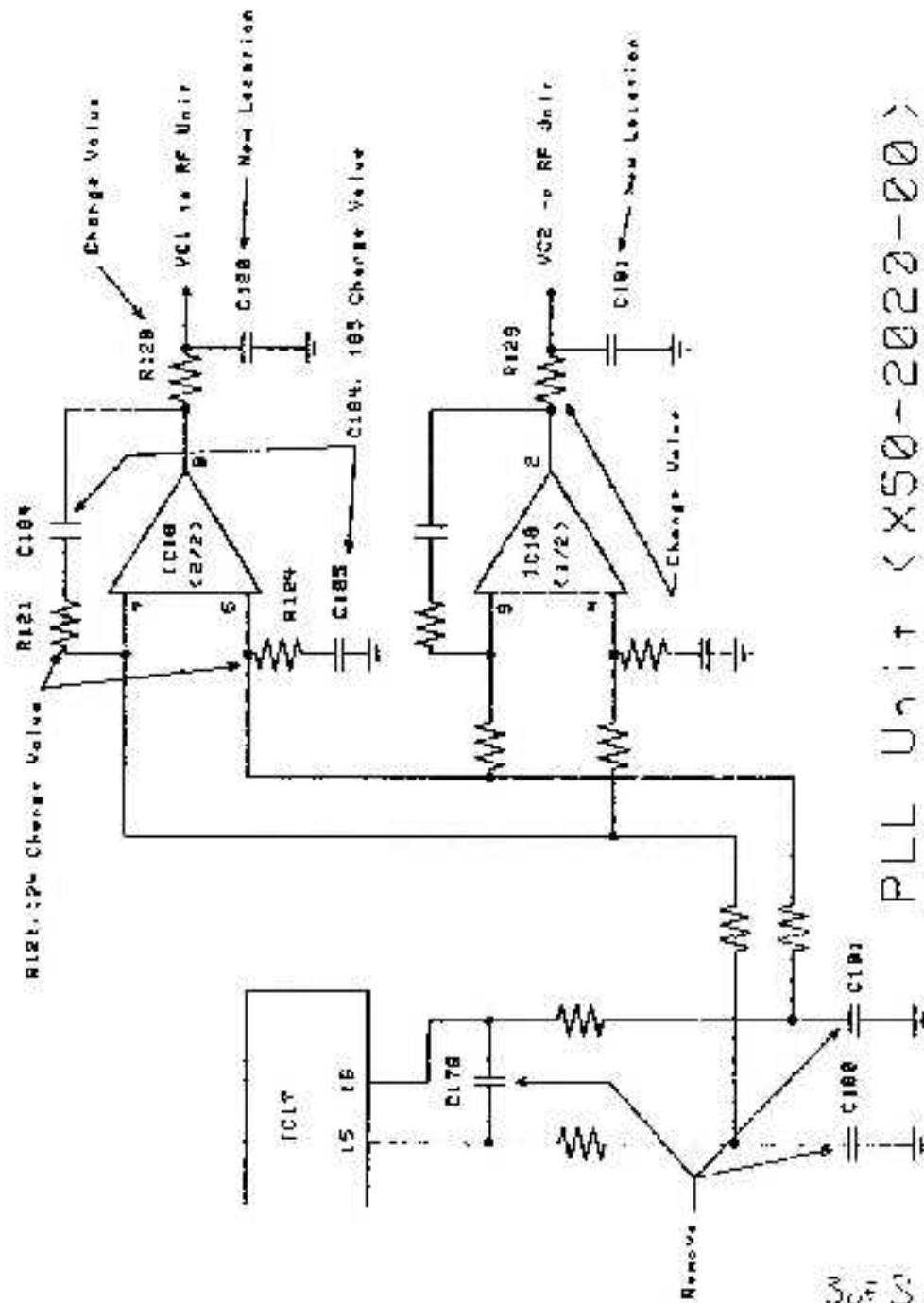

3 of 5

PLL Unit (X50-2020-00)

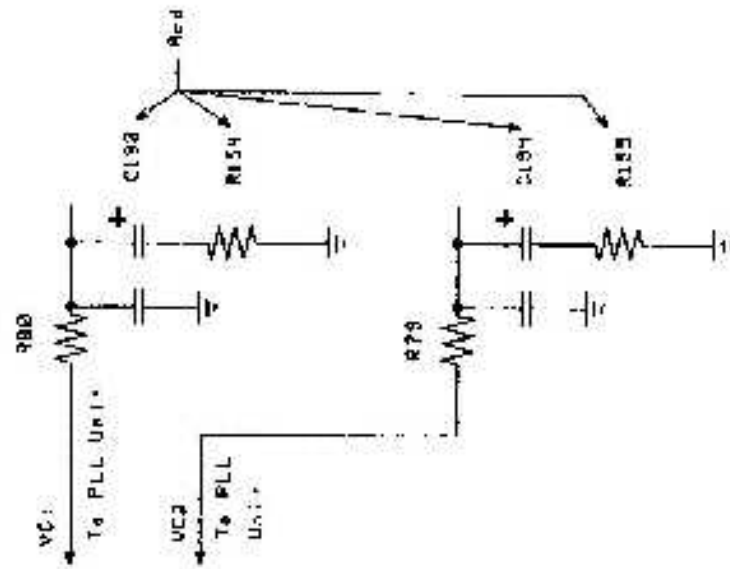

RF Unit (X44-1560-20)

KENWOOD

918

SERVICE BULLETIN AMATEUR RADIO

| SUBJECT | DATE |
|---------------------------------|---------|
| TS-940S SQUELCH SWITCHING NOISE | 7-21-87 |

In some TS-940S below S/N 711xxxx, a "popping" or "clicking" noise may be heard when the squelch circuit is opened or closed. This may be more noticeable when an optional CW filter is installed. The following procedure will minimize the noise.

Parts required

| | | |
|----------|--------------------------------|--------------|
| R194 | 560K ohms 1/6W..... | RD14CB2C564J |
| R197 | 220 ohms 1/6W..... | RD14BB2C221J |
| R355,356 | 220K ohms 1/6W..... | RD14BE2C224J |
| C284 | 0.47 uF, 50V electrolytic..... | C90-0484-05 |

Procedure:

1. Disconnect the power cord and antenna from the transceiver.
2. Remove the top and bottom covers (16 screws).
3. Locate the I.F. board on the bottom of the transceiver.
4. Remove the 7 screws from the I.F. board.
5. Carefully unplug connector # 17 (right side of optional CW filter) by prying up on the plug. Do not pull on the wires.
6. Move the 4 wires (yel, org, brn, red) that run across the far side of the I.F. unit out of the way so the board may be removed.
7. Carefully lift and rotate the board toward the left side of the transceiver to expose the foil side of the board.
8. Using a small craft knife, cut the foil at the 3 points shown in figure 1 (top right corner of the board).
9. Unsolder and discard resistors R194 and R197. They are mounted on the component side of the board and soldered on the foil side.
10. Install a 560K ohm resistor on the component side of the board as shown in figure 2. This resistor is now designated as R194.

11. On the foil side of the board, add the 3 resistors (R197, 355, 356) as shown in figure 3.
12. Add a small jumper wire as shown in figure 3.
13. Add capacitor C282 as shown in figure 3. Observe polarity and insulate the positive (+) lead with shrink tubing.
14. Carefully place the board in its original position (do not pinch wires) and secure it with the 7 screws.
15. Plug in connector # 17. Move the 4 wires on the far side of the board back to their original position.
16. Put the covers back on the TS-940S and secure them with the 16 case screws.
17. Connect the antenna and power cord then test the transceiver for normal operation.

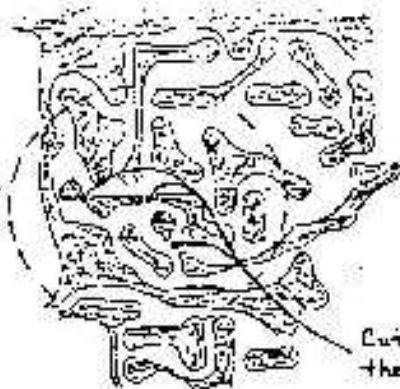

FIGURE 1

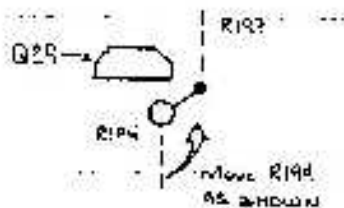

FIGURE 2

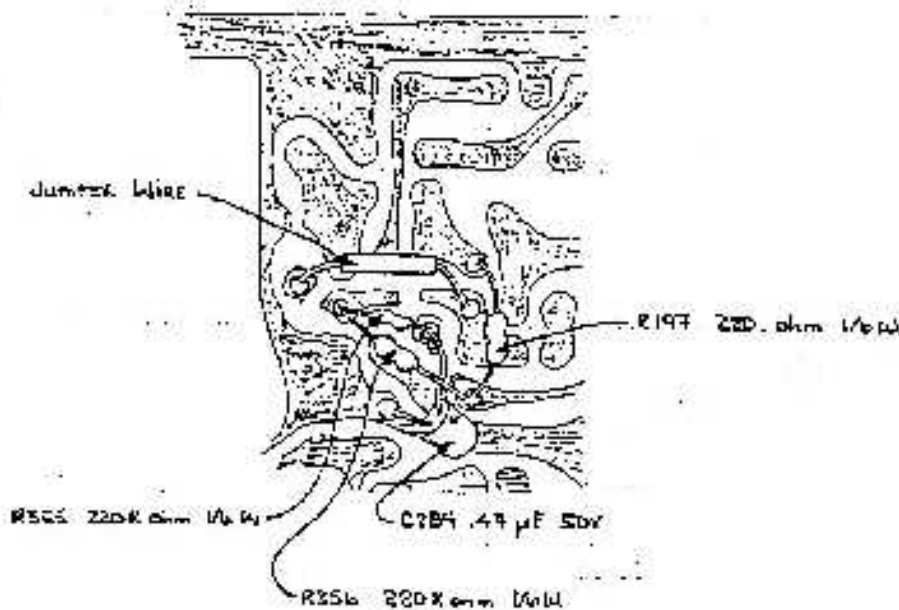

FIGURE 3

This is an optional change that may not be performed under warranty. Time required for this modification is 1.0 hrs or less. (C)0722B7TKC



SERVICE BULLETIN

from: TRIO-KENWOOD COMMUNICATIONS, INC.

TR-2400

#818

SUBJECT: TR-2400 "SCRATCHY" TX

DATE 3/20/80

Complaints of "scratchy" audio, noise when flexing the antenna, or noisy audio when handling the unit during transmit may be remedied by tightening PCB screws.

To disassemble the unit remove the back cover and battery compartment screws. Inspect the VCO shield solder points along the edge and bottom of the PLL board. Resolder if you find a broken solder bond.

Flex the metal frame several times to reseat the board, and retighten the board mounting screws. Be certain the flat metal spring has good tension when installed between the RX TX unit and frame (below the PTT switch).

JRS/yr
encl:

KENWOOD

921

SERVICE BULLETIN AMATEUR RADIO

| SUBJECT | DATE |
|------------------------------------|---------|
| TS-940S SSB TALK POWER IMPROVEMENT | 7/22/87 |

TS-940S in the serial number range of 601xxxx through 708xxxx may be limited in SSB peak power as compared to full CW output. The level may be increased by changing the value of capacitors C182 and C183 in the ALC circuit on the Control board. The recommended replacement value for each capacitor is 0.0022 uF, 50V (PART # CK45B1H222K).

Procedure:

1. Disconnect the power cord and antenna from the transceiver.
2. Remove the top and bottom covers (16 screws).
3. Locate the Control board on the bottom of the transceiver.
4. Locate transistor Q37 on the board (toward the back right hand side). The two capacitors are mounted on the foil side of the board underneath Q37.
5. To access the bottom of the board remove the 8 screws that mount the board and heat sink to the chassis (See figure 1).
6. Carefully lift the board/heat sink from the right hand side and pivot it toward the front of the transceiver.
7. Replace C182 and C183 with 0.0022 uF, 50V capacitors (see figure 2 for PC board view).
8. Lower the board/heat sink back into its original position (do not pinch any wires) and re-install the 8 mounting screws.
9. Put the covers back on the TS-940S and secure them with the 16 case screws.
10. Connect the antenna and power cord then test the transceiver for normal operation.

This is an optional change that may not be performed under warranty. Time required for this modification is 1.0 hrs or less. (C)072287TKC

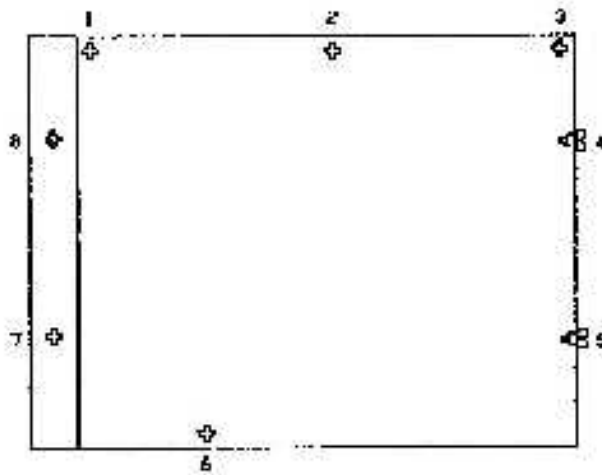

FIGURE 1

C182, 183

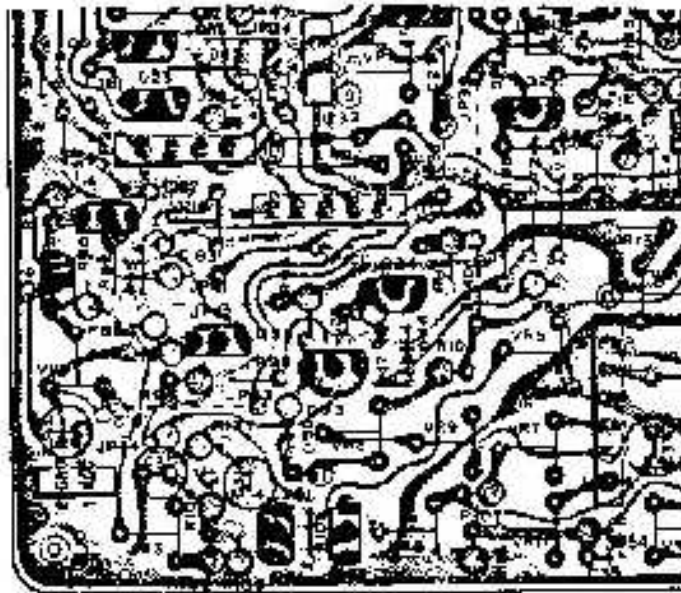
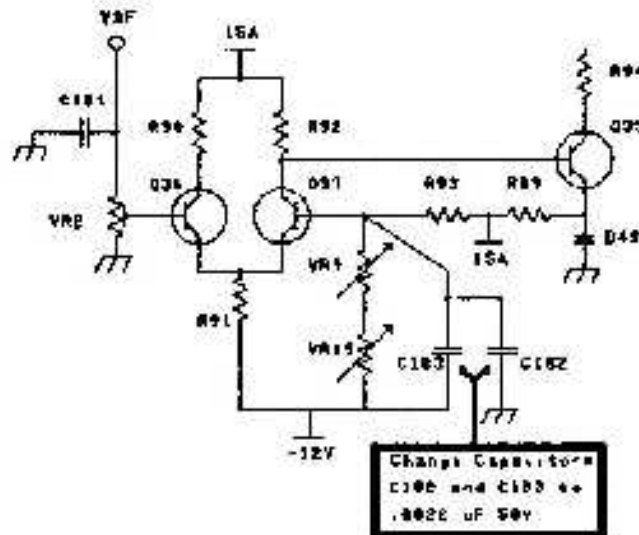

FIGURE 2



X53-1420-00
Control Unit

KENWOOD

SB-951

SERVICE BULLETIN AMATEUR RADIO

| | |
|------------------------------------|------------------|
| SUBJECT TS-940S ERRATIC DISPLAY | DATE 01/20/89 |
|------------------------------------|------------------|

Intermittent control or display problems that are difficult to correct with the reset procedure may be caused by a faulty ROM socket. The socket should be checked to insure that it makes good electrical contact with each pin of the ROM. If it is found to be intermittent, remove the socket and solder the ROM directly to the board. It should be noted that units between serial numbers 701XXXX to 811XXXX and from 903XXXX to 909XXXX are not likely to have this failure. In addition, units with a serial number of 909XXXX and above do not incorporate a socket.

CAUTION

Removing the socket requires good soldering skills. The ROM is mounted on the Digital A unit and is designated as IC2. The board, being double sided, has solder connections on both component and foil sides. When the socket is removed, it is very important to insure that each pin is completely solder free. Having to pry up on the socket means that it is not completely desoldered and will cause the circuit foils to tear.

When performing any work on the Digital A board, CMOS handling techniques must be observed. Such techniques include using a grounded or isolated soldering tip, avoid touching the pins of IC chips with your fingers, and ground yourself with a wrist ground strap.

To remove the socket:

1. Disconnect the power cord and antenna coax.
2. Remove the top and bottom covers from the transceiver.
3. Remove the 2 flat head screws from each side of the front panel chassis.
4. Loosen the round head screw on each side of the front panel chassis.
5. Carefully rotate the front panel forward. It will be necessary to unplug the VS-1 cable from the transceiver.
6. Remove the 4 screws from the speaker mount.

7. Carefully pull up on the mount and rotate it toward the front panel. Swing the mount toward the right side of the transceiver and allow it to rest on the Digital B unit shield.
8. Remove the 8 screws from the Digital A unit shield plate.
9. Lift the plate and rotate it to the left side of the transceiver.
10. While avoiding contact with the pins, remove the ROM (IC2) and set it aside on anti-static foam.
11. Remove the 6 screws that mount the Digital A board. Rotate the board toward the front panel to expose the bottom side of the board.
12. Carefully desolder the socket and remove it from the board. Do not pry up on the socket. If it does not easily pull off the board, the top foils are still soldered to the socket.
13. Install the ROM in the board and solder it in place.
14. Assemble the transceiver by reversing steps 1 - 11. Do not pinch the power switch cables between the front panel and the body of the transceiver.

**This modification may be covered under warranty during the warranty period.
Time required for this modification is 1.5 hrs or less. (C) 011189TKC**

SERVICE BULLETIN Amateur Radio Division

| | |
|--------------------------------------------------------|------------------------------|
| SUBJECT TS-940S MRF-485 Driver Transistor Notes | DATE January 16, 1992 |
|--------------------------------------------------------|------------------------------|

Some MRF-485 transistors are being supplied by Motorola with a Green or Blue color ranking. If these transistors are installed without modifying the driver bias circuit there is a very strong possibility that they will fail within a very short time frame.

These high gain transistors cause the circuit to become unstable which can cause the circuit to break into self oscillation, and therefore self-destruct.

Recommendations:

Use of Red, Orange, or Yellow hfe color rankings is recommend. These lower gain transistors work just fine and do not suffer from the circuit instability problem. If you are only able to obtain the higer gain transistors you will need to modify the varistor/temperature compensation circuit on the final unit (X45-1400-00) by changing R16 from 1.2K to 2.2K ohms.

During its production the TS-940S used two different varistor values. The original part was an STV3H (O). It was changed in mid-production to an SV-03YS. R15 was changed from an 820 ohm resistor to a 1K ohm resistor at the same time. Therefore the countermeasure differs depending upon the serial number of the radio.

| Serial number lot | Varistor D2 | R15 | R16 | MRF485 Green or higher rank |
|--------------------|-------------|-----|------|-------------------------------|
| 106XXXX or earlier | STV3H(O) | 820 | 1.2K | See "Caution below" |
| 107XXXX or later | SV-03YS | 1K | 2.2K | Change R16 from 1.2K to 2.2 K |

Caution: If using a Green or higher hfe rank one of the above countermeasures must be taken depending upon the serial number of the set. After replacing the drivers check the bias current. We recommend transmitting for 1 hour in the SSB mode with no modulation into a dummy load. After this time frame check the bias current. It must not exceed 300 mA on the original radio. If the current changes you must change R16 from 1.2K to 2.2K.

MRF405 hfe Color Codes

| Color Range | Limits | |
|-------------|--------|-----|
| | MIN | MAX |
| Red | 20 | 32 |
| Orange | 20 | 42 |
| Yellow | 30 | 52 |
| Green | 48 | 63 |
| Blue | 50 | 70 |
| Violet | 72 | 93 |

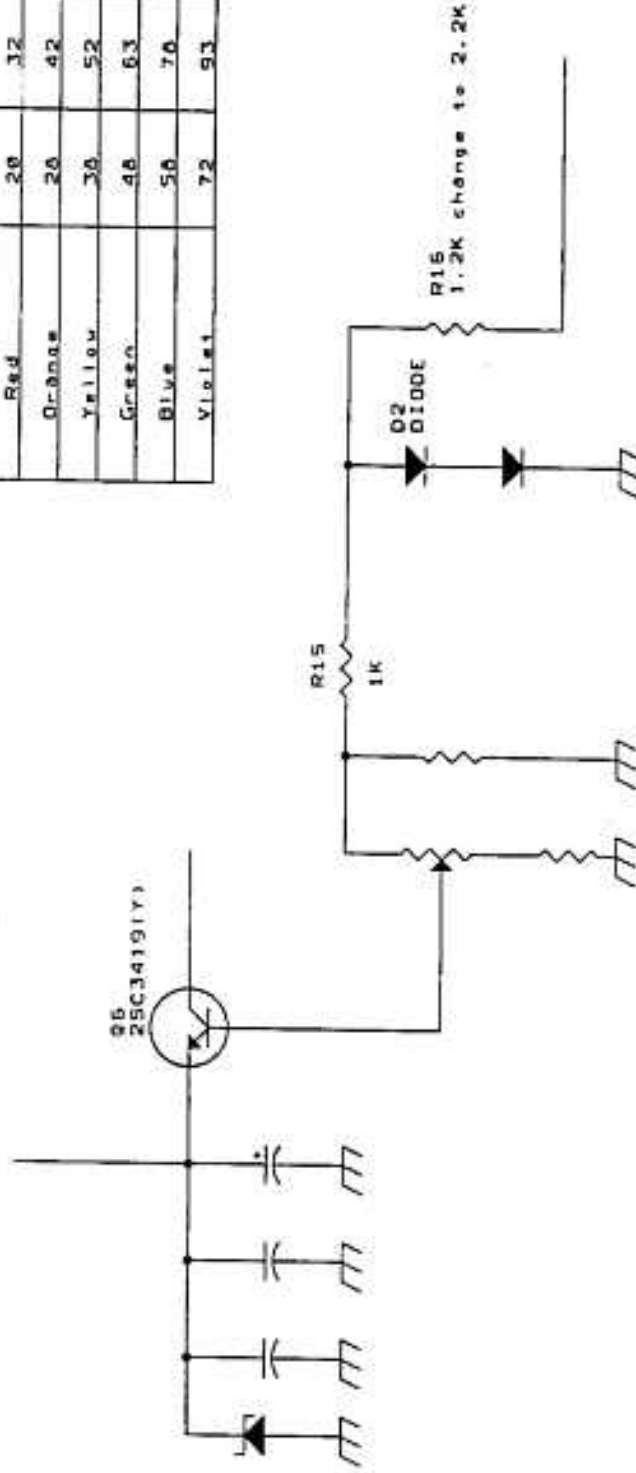

Kenwood, U.S.A.
 2201 E. Dominguez Street
 Long Beach, CA 90801-5705

Title TS-0405 MRF-405 Driver Transistor

Site Document Number SB-980

Date: January 21, 1992 Sheet 1

REV

CONTROL UNIT
X 53-1240-XX

ADD

* Mounted on foil side.

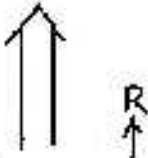
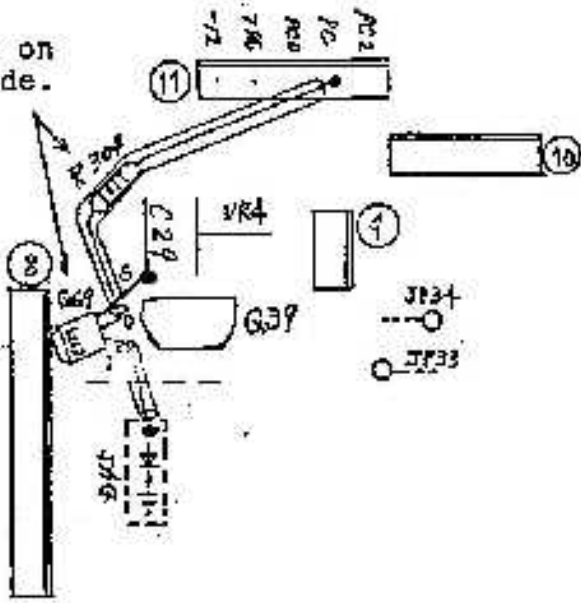

Component side view.

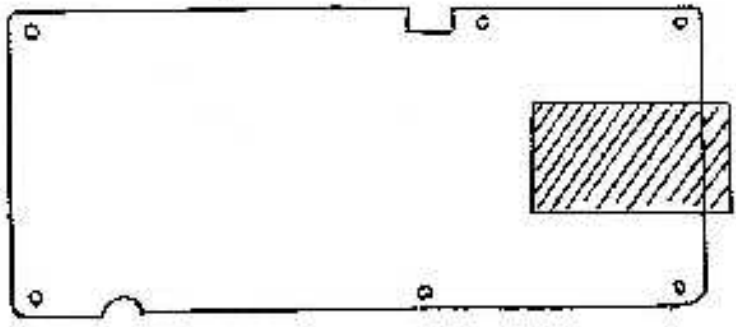

SERVICE BULLETIN

AMATEUR RADIO

| | |
|------------------------------------------------|-----------------------|
| SUBJECT TS-940S ANTENNA TUNER RELAYS | DATE 4-4-86 |
|------------------------------------------------|-----------------------|

Occasionally during operation of the AT-940 a VSWR of greater than 1.5 to 1 might cause overloading of the relay contacts in the antenna tuner. This may be especially noticeable when switching BANDS, or if TUNING is performed too frequently. The following procedure should reduce or eliminate this tendency.

Parts Required

- Q69: Digital Transistor DTC124ES
 R304: 5.6K ohm 1/6 W Resistor RD14BB2C562J

Procedure:

1. Add the circuit as shown below.
2. After the circuit has been installed adjust VR4 for a 10-15 watt output when the antenna tuner operates.

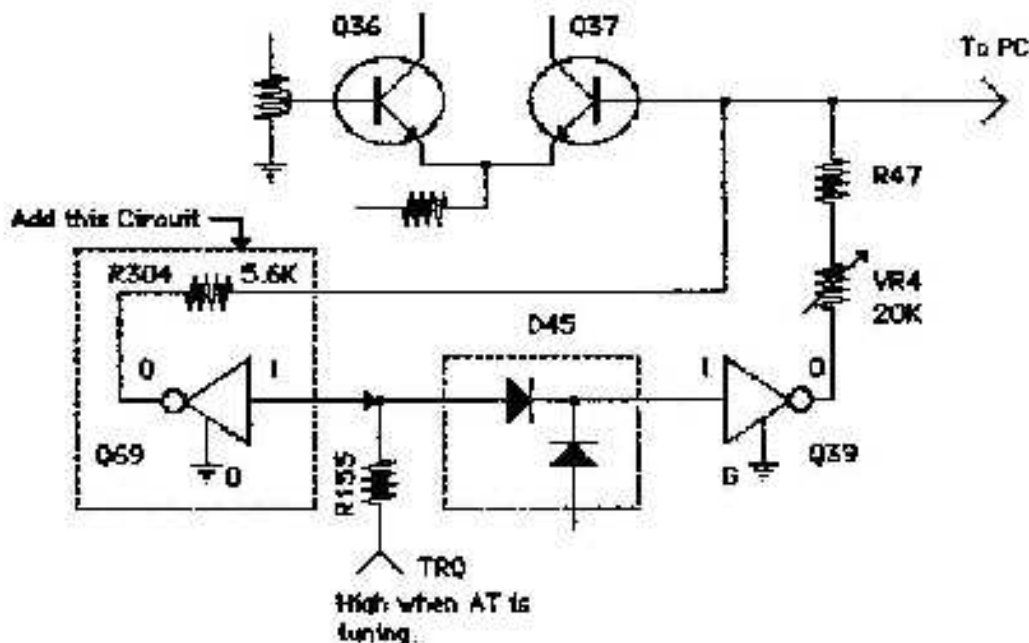

SERVICE BULLETIN

AMATEUR RADIO

| SUBJECT | DATE |
|--------------------|--------|
| TS-940S PLL UNLOCK | 4-8-86 |

Reports of a PLL Unlock on the lower frequencies may be due to low VCO levels. The following change will increase the VCO level and should prevent recurrence of this symptom.

Part Required

C168.....change to 15 pF 50 v (CC45SL1H150J)

Procedure:

1. On the RF Unit (X44-1660-00) change C168 from a 33 pF capacitor to a 15 pF 50 v capacitor.
2. Readjust the VCO BPF (RF unit L74-76) according to the instructions contained in the TS-940S service manual.

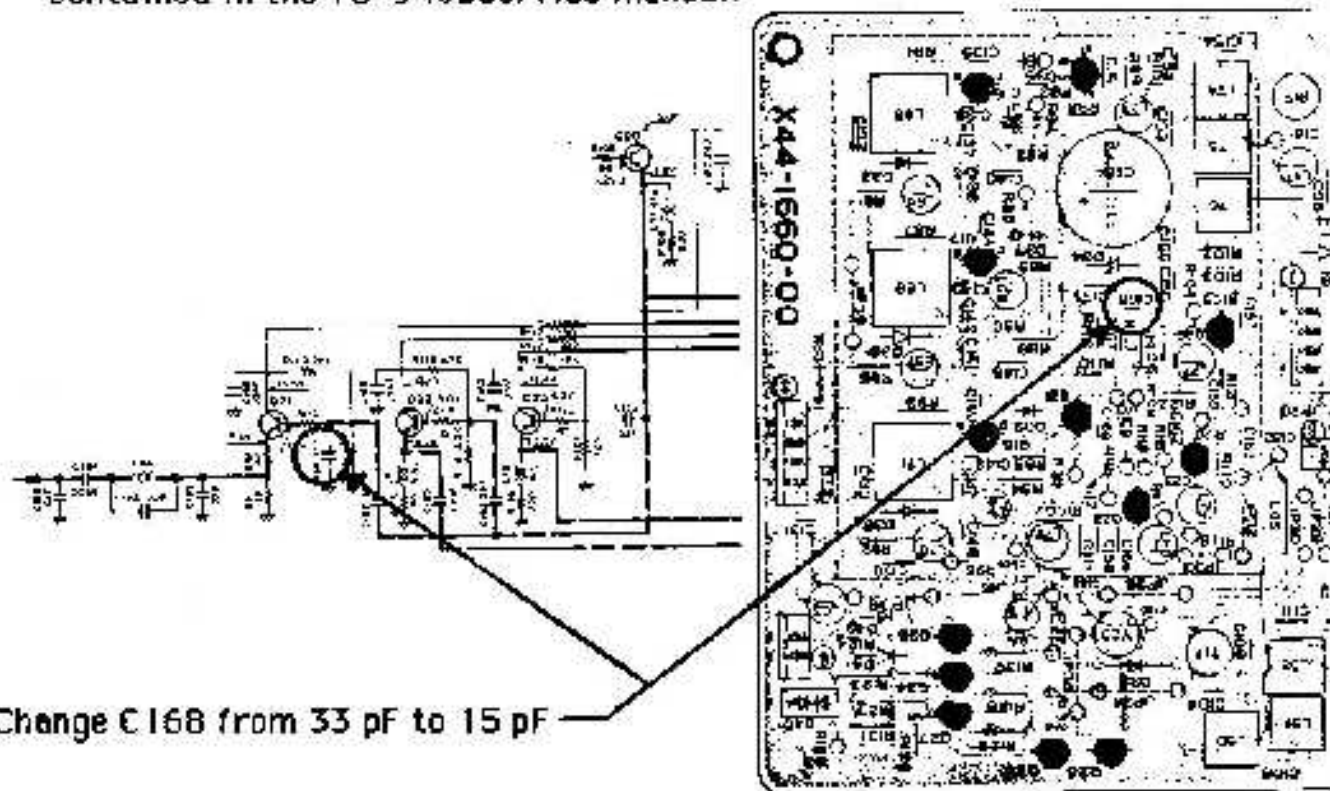

This change is applicable to units prior to serial number 606XXXX.

Time Required for this modification is 1 hour or less. ©TKC40886CLM